

## Using the Evaluation Board

The ISL6443 is a high performance triple-output controller offering control and protection features for 2 synchronous buck PWMs and 1 linear regulator.

The ISL6443 evaluation board highlights the operation of the IC in an embedded DC/DC converter application. Table 1 shows the available evaluation board.

**TABLE 1. EVALUATION BOARDS**

BOARD NAME	IC	PACKAGE
ISL6443EVAL2Z	ISL6443IRZ	28 Ld QFN

## Recommended Test Equipment

- A 12V, 5A capable power supply
- An electronic load
- Four channel oscilloscope with probes
- Precision digital multimeters

## Power and Load Connections

### Input Voltage

To connect a +12V power supply to the evaluation board, connect the positive lead of the power supply to the VIN (P1) post and the ground lead of the supply to the GND (P2) post.

The input voltage to the linear controller is already taken from the 1.8V output of V<sub>OUT2</sub>.

### Output Adjustment

Change the respective output voltage feedback resistors to modify the output voltage using Equation 1:

$$\begin{aligned}
 V_{OUT1} &= 0.8 \cdot \left( 1 + \frac{R_1}{R_2} \right) & V_{OUT2} &= 0.8 \cdot \left( 1 + \frac{R_3}{R_4} \right) \\
 V_{OUT3} &= 0.8 \cdot \left( 1 + \frac{R_6}{R_{11}} \right) & &
 \end{aligned}
 \tag{EQ. 1}$$

### Soft-Start and Shutdown

The soft-start capacitors can be adjusted for sequencing of the output voltages, PWM start-up tracking, and/or to adjust the start-up current required to charge the output capacitors.

$$\begin{aligned}
 t_{SS(PWM1)} &= C_2 \cdot \frac{0.8V}{5\mu A} & t_{SS(PWM2)} &= C_3 \cdot \frac{0.8V}{5\mu A}
 \end{aligned}
 \tag{EQ. 2}$$

To independently shutdown the PWMs, the SD1 or SD2 pin can be pulled to GND using the on-board posts, P9 and P10 respectively.

### Power Good

When both PWMs are within  $\pm 10\%$  of their set value and the linear regulator output is within 75% of its set value, the PGOOD signal will go high. The open drain PGOOD pin is pulled HIGH to VCC\_5V on the board. The PGOOD circuitry monitors the FBx pin of each regulated output to determine if the outputs are in regulation. PGOOD can be monitored at post P8.

### Overcurrent Protection

The overcurrent thresholds can be adjusted on the ISL6443 evaluation board. The current sense resistors, I<sub>SENSE</sub>, are set at 1.0k $\Omega$ . The overcurrent set resistor is 95.3k $\Omega$ . The overcurrent trip point can be adjusted by modifying R<sub>OCSET</sub>, R<sub>5</sub> and R<sub>10</sub>:

$$R_{OCSET} = \frac{7 \cdot R_{CS}}{I_{OC} \cdot r_{DS(ON)}} \tag{EQ. 3}$$

R<sub>OCSET</sub> is the overcurrent set resistor, R<sub>CS</sub> is the current sense resistor, I<sub>OC</sub> is the desired overcurrent trip point, and r<sub>DS(ON)</sub> is the ON-resistance of the respective PWM's lower MOSFET. Refer to the ISL6443 Data Sheet for more information on how to select the current sense and overcurrent select resistors.

# ISL6443EVAL2Z Schematic

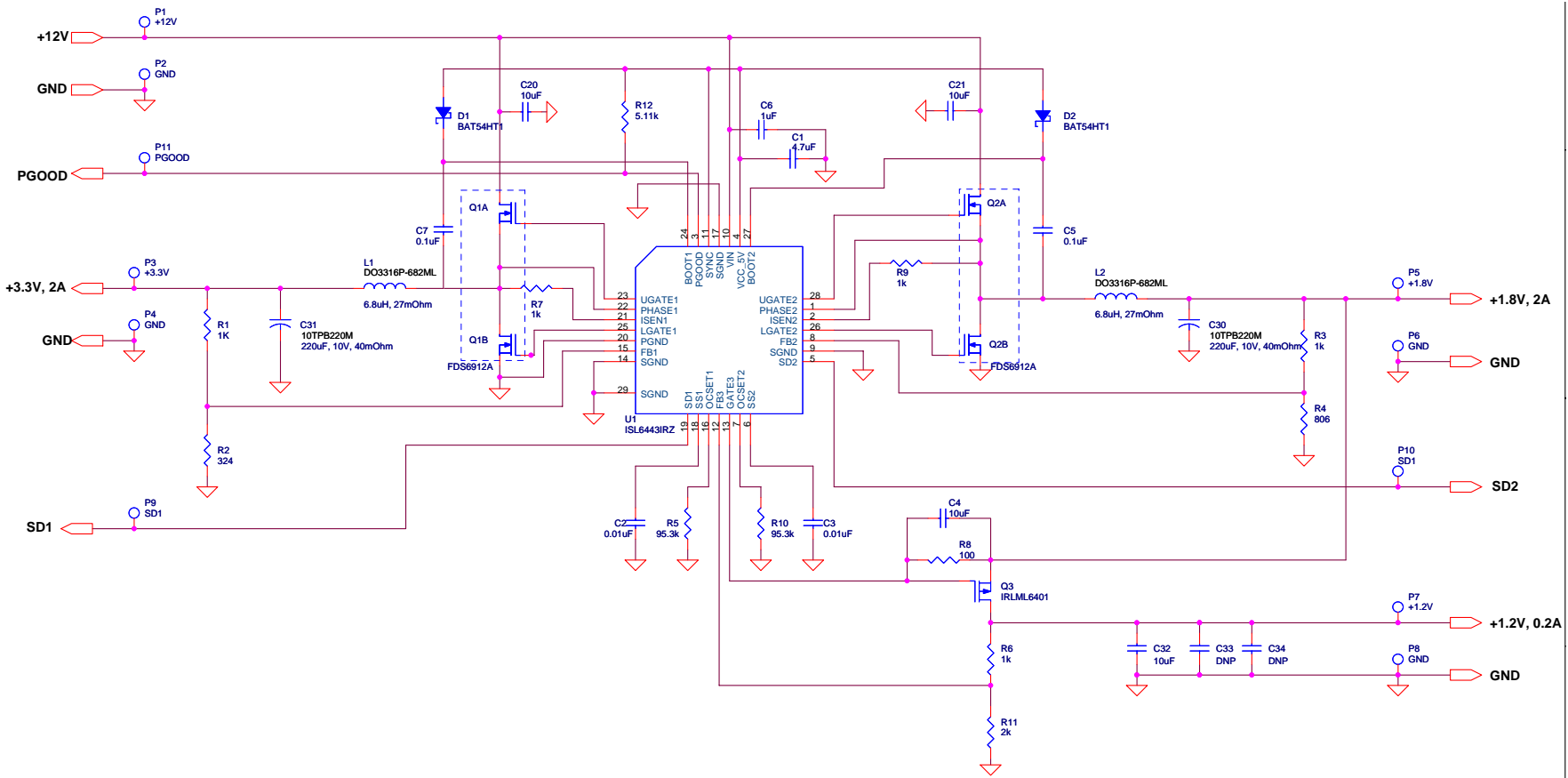

**ISL6443EVAL2Z Bill of Materials**

ITEM	REFERENCE	QTY	PART NUMBER	PART TYPE	DESCRIPTION	VENDOR
1	P1 to P12	12	1514-2	Test Point	Turret 0.281 Height	Keystone
2	D1, D2	2	BAT54HT1G	Diode, Schottky	30V, 200mA	On Semi
3	C4	1	C1608X5R0J106	Cap, Ceramic, X5R	10µF, 6.3V, 0603, X5R	TDK
4	C30, C31	2	10TPB220M	Cap, POSCAP	220µF, 10V	Panasonic
5	C20, C21	2	C3225X5R1C106KT	Cap, Ceramic, 1210	10µF, 16V, 1210, X5R	TDK
6	L1, L2	2	DO3316P-682ML	SMT Power Inductor	6.8µH, ±20%, 4.6A, 27mΩ	Coilcraft
7	C1	1		Capacitor, Ceramic, 0603	4.7µF, 20%, 6.3V, 0603	Generic
8	Q1, Q2	2	FDS6912A	Dual NFET	6A, 30V, Dual NFET, SO8	Fairchild
9	C5, C7	2		Cap, Ceramic, 0603	0.1µF, 10%, 16V	Generic
	C2, C3	2		Cap, Ceramic, 0603	0.01µF, 10%, 16V	Generic
10	C6	1		Cap, Ceramic, 0603	1.0µF, 10%, 16V	Generic
11	C32	1		Cap, Ceramic, 0805	10µF, 10%, 6.3V	Generic
12	C33, C34	2			NOT POPULATED	-
13	R8	1		Resistor, Film	100Ω, 0603, 1%, 1/16W	Any
14	R1, R3, R6, R7, R9	5		Resistor, Film	1kΩ, 0603, 1%, 1/16W	Any
15	R11	1		Resistor, Film	2kΩ, 0603, 1%, 1/16W	Any
16	R2	1		Resistor, Film	324Ω, 0603, 1%, 1/16W	Any
17	R5, R10	1		Resistor, Film	95.3kΩ, 0603, 1%, 1/16W	Any
18	R12	1		Resistor, Film	5.11kΩ, 0603, 1%, 1/16W	Any
19	R4	1		Resistor, Film	806Ω, 0603, 1%, 1/16W	Any
20	Q3	1	IRLML6401PBF	Single NFET	Power MOSFET	IR
21	U1	1	ISL6443IRZ	300kHz, Dual PWM Controller		Intersil

**ISL6443EVAL2Z Layout**

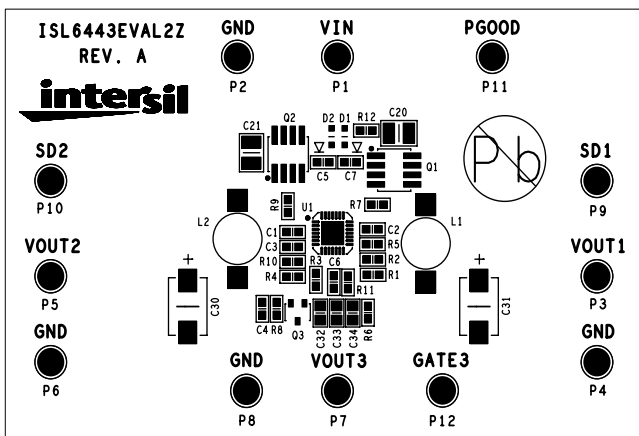

FIGURE 1. TOP SILK

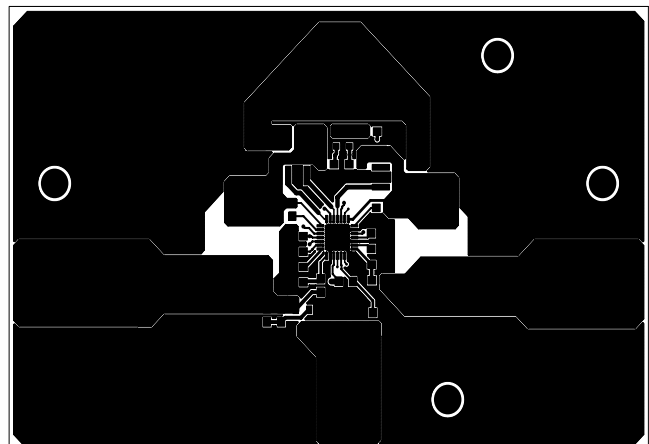

FIGURE 2. TOP LAYER

ISL6443EVAL2Z Layout (Continued)

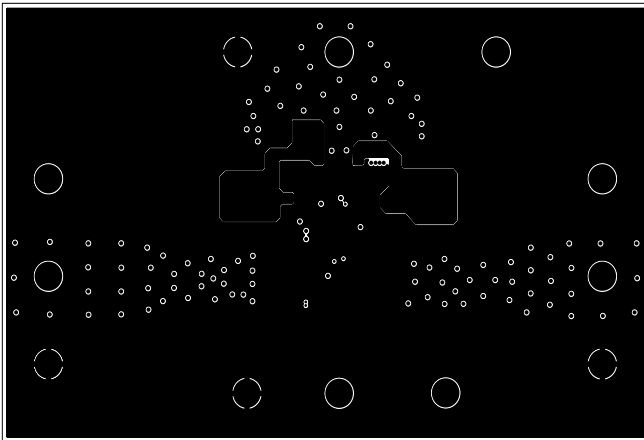

FIGURE 3. LAYER 2

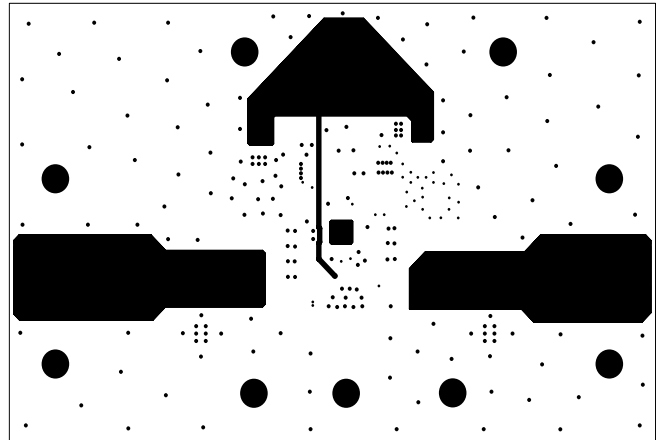

FIGURE 4. LAYER 3

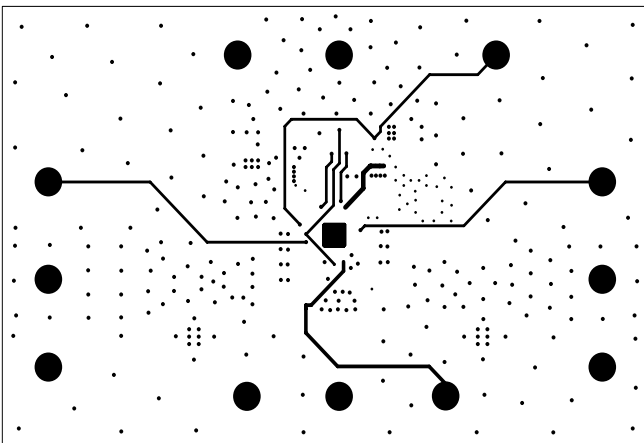

FIGURE 5. BOTTOM LAYER

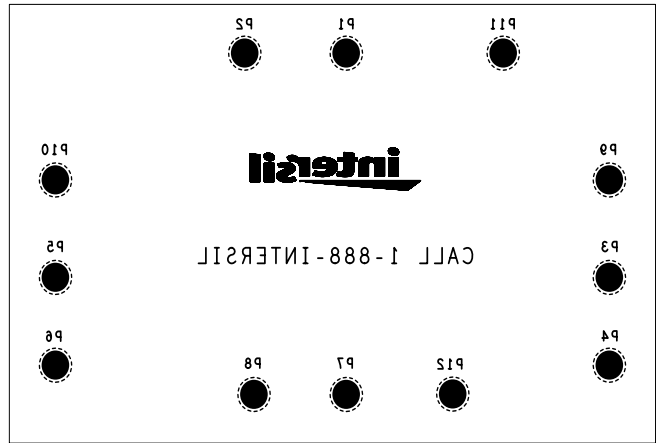

FIGURE 6. BOTTOM SILK

Intersil Corporation reserves the right to make changes in circuit design, software and/or specifications at any time without notice. Accordingly, the reader is cautioned to verify that the Application Note or Technical Brief is current before proceeding.

For information regarding Intersil Corporation and its products, see [www.intersil.com](http://www.intersil.com)